



FEATURES AND BENEFITS

Ultra High-Performance Toolpath Engine

Version 3.5

VoluMill™, a plug-in toolpath engine that works with any CAM system, produces Ultra High-Performance Toolpaths to be used in place of traditional and contemporary roughing methods when simplified programming, reduced cycle times, extended tool life, and reduced stress on machine tools are desired.

VoluMill toolpaths establish and maintain ideal machining conditions throughout the roughing process, enabling your machine tools and cutting tools to operate safely and efficiently to their full capabilities.

Extracting the maximum performance from your machining assets boosts profitability and increases shop capacity without adding capital equipment.

Unique Engineered Features

VoluMill's novel rough-milling toolpaths remove material in the most effective way possible. This patent-pending technology generates toolpaths that never exceed a desired material removal rate, regardless of a part's shape. Pockets, open shapes, cores, and cavities, with or without islands, are all handled with great efficiency. The toolpaths are effective in any material, from aluminum to tool steels, stainless steels, titanium, and high-temperature alloys.

The constant radial depth of cut, derived from the user-specified stepover, keeps an even and predictable load on the cutting tool, enabling the safe use of faster spindle speeds, faster feedrates, and deeper axial depths of

cut, resulting in reduced cycle times and extended cutting tool life.

Constant cut spacing ensures a full floor cleanup in any part shape when large stepover values are used, even in acute angles, with no additional user input or tool motion.

VoluMill toolpaths contain no sharp corners, so the tool never becomes overloaded. The smooth, flowing motion ensures that tool or table travel never needs to stop for abrupt directional changes. Consequently, the repeated acceleration and deceleration requirements so common to ordinary toolpaths are eliminated.

Connections between cuts always take place in previously-milled transition areas, with the tool completely

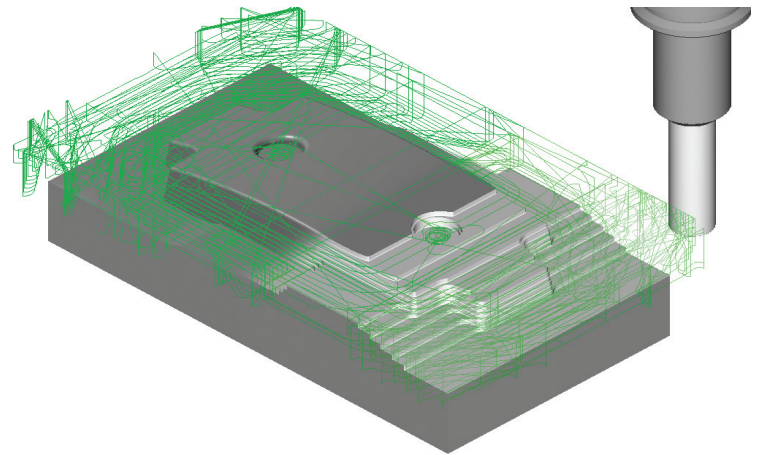
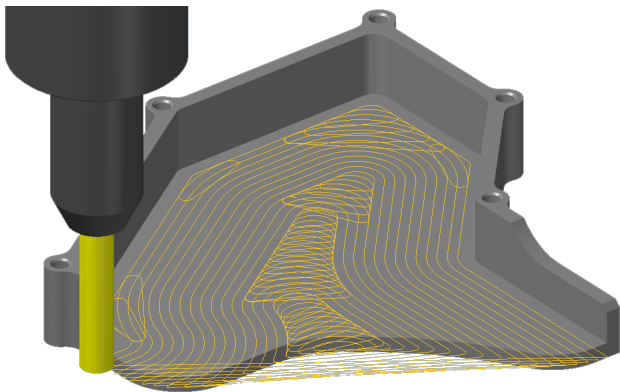

VoluMill toolpaths produce a consistent material removal rate, using smooth, flowing motion to establish and maintain ideal milling conditions in any part shape. Reduced forces on the spindle and cutting tool enable machining hardware to be safely utilized to its full capabilities. Uniform chip formation and excellent heat dissipation result in the previously unachievable combination of dramatically reduced cycle times and significantly extended cutting-tool life.

VoluMill™ substantially reduces cycle times and tool wear on complex mold and die applications. Intuitive interface handles cavities, cores, and rest milling in hard and soft materials.

disengaged from the material. As such, these moves are executed at the machine's fastest possible feedrate. In addition, the tool is lifted slightly during these moves to avoid dragging it along an already-milled floor or catching a chip.

Feedrates are dynamically adjusted in counterclockwise arcs (when climb milling; clockwise arcs if conventional milling) to maintain a constant material removal rate even as the engagement angle between the tool and material increases in such circumstances.

Full-width slot milling – the use of which is enabled or disabled at the user's discretion – can be quite effective in softer materials. Even here, the MRR does not increase, since VoluMill automatically adjusts the axial depth of cut and/or feedrate to maintain the desired material removal rate.

When necessary, material entry is performed at an automatically reduced feedrate to prevent micro fractures in the substrate of the cutting tool.

3-Axis Innovative Features

INLINE RESTMILL™

VoluMill's 3-axis roughing strategy offers the use of two, distinct depths of cut within the same toolpath. First, deep axial cuts, up to the full flute-length of the tool, can be used to remove the bulk of the material as quickly as possible. A second, smaller depth of cut can also be set to leave a perfectly uniform, user-specified final step height on the model. This strategy minimizes roughing and overall cycle times, roughs the part to a near-net shape, and requires the use of fewer tools.

PARALLEL PROCESSING

Designed for parallel processing, VoluMill takes full advantage of the multi-core capabilities of your computers.

REGIONALIZATION

Cutting motion is localized to minimize tool repositioning.

UNDERCUT PROTECTION

Vertical concavities in the geometry will not cause gouges in the part.

REST MILLING

Subsequent, smaller tools use VoluMill toolpath motion to machine only where previous, larger tools could not fit.

INTELLIGENT SORTING

VoluMill provides options to machine individual areas to full depth before moving to the next area, or to machine the entire part one depth at a time.

FEATURE	BENEFITS
Managed Material Removal Rate Strategy	<ul style="list-style-type: none"> • Produces the best roughing toolpath in all situations • Optimizes machine tool and cutting tool utilization
Ultra High-Performance Toolpaths	<ul style="list-style-type: none"> • Maintain a consistent material removal rate • Keep parts and cutting tools cool • Generate reduced forces on the machining setup • Dissipate heat with the chips • Allow use of smaller diameter, less expensive and more widely applicable cutting tools
Automatic feedrate adjustment	<ul style="list-style-type: none"> • Maintains desired material removal rate throughout the part program
Automatic depth of cut adjustment	<ul style="list-style-type: none"> • Prevents exceeding the desired material removal rate
Freeway Linking™	<ul style="list-style-type: none"> • Leverages previously-unused machine capabilities • Keeps the tool closer to the work
High-speed repositioning	<ul style="list-style-type: none"> • Minimizes cycle time
Repositioning clearance	<ul style="list-style-type: none"> • Enables high-speed repositioning • Prevents dragging the tool across an already-machined surface
Stepover up to 100 percent of tool diameter	<ul style="list-style-type: none"> • Ensures complete floor cleanup when large stepovers are used • Very beneficial when machining shallow areas • Expands programming flexibility
Smoothing radius	<ul style="list-style-type: none"> • Eliminates sharp directional changes • Keeps tool motion flowing smoothly • Controls extent of machining in tight areas
Contour ramping	<ul style="list-style-type: none"> • Provides safe access into tight areas
Regionalization	<ul style="list-style-type: none"> • Minimizes tool repositioning and overall cycle time
Undercut protection	<ul style="list-style-type: none"> • Prevents gouging
Parallel processing	<ul style="list-style-type: none"> • Leverages multi-core capabilities for faster computation

For more information and to take advantage of the 15-day free trial offer, visit the VoluMill™ Web site at www.volumill.com

Copyright © 2010 Celeritive Technologies, Inc.

VoluMill™, Freeway Linking, InLine RestMill™, and SmartRamp™ are trademarks of Celeritive Technologies, Inc.

